

Lakefront

By: Danielle Leone



Prints as shown may not be to exact scale.



A 3017-27680-741
Apron Front
 1 1/8 yds. (directional)



B 3017-27682-427
Pocket
 1/2 yd.



C 3017-27686-444
Binding
 3/8 yd. (or Fat Quarter)



D 3017-27681-447
Lining
 1 yd.



BASIC Apron #1 Featuring Lakefront

Please read all instructions carefully AND identify all fabrics before beginning.

All instructions include a 1/4" seam allowance and strips are cut selvage to selvage, unless stated otherwise.

1. Cut the following:

Fabric A - Cut (1) 31" wide x 34" tall rectangle for apron front

Fabric B (stripe print) - Referring to the apron image, fussy cut (1) 14" x 31" multi-stripe strip the length of fabric parallel to selvage (allow 1-1/2" for hem across top)

- OR -

Fabric B (non-directional print) - Cut (1) 14" strip, subcut (1) 14" x 31" strip

Fabric D - Cut (1) 31" wide x 34" tall rectangle for apron lining

2. Piecing Order:

1. Fold **Fabric A** rectangle in half lengthwise, right side out. Mark edge of fabric as shown with arrows. Draw lines as shown with dashed lines.

Shading of diagrams may vary depending on fabrics used.

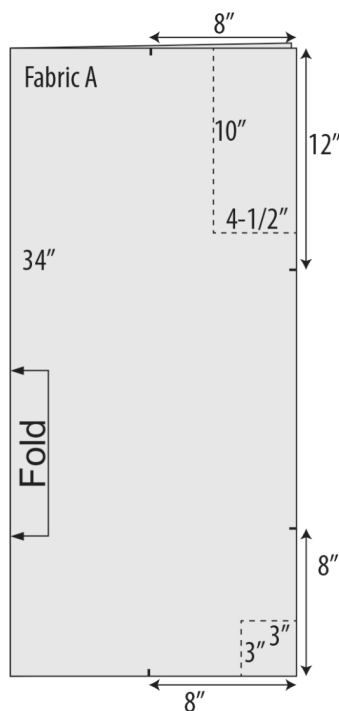
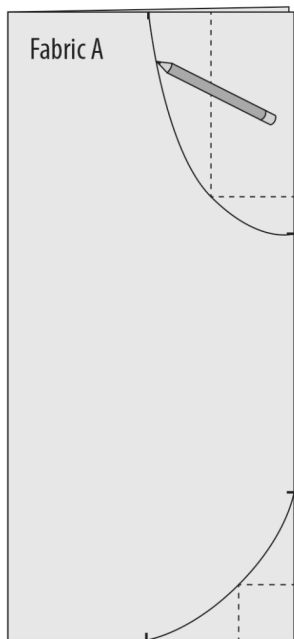

2. Draw a smooth curve for the armhole from the mark on top, to the corner of the dashed lines, and to the mark 12" down the side. In the same manner, create a smooth curve on bottom corner.

3. Cut out armhole and bottom curve through both layers of folded **Fabric A** rectangle.

4. Fold 31" top edge of **Fabric B** strip 1/2" to wrong side and press. Fold to wrong side again 1" and press flat. Topstitch close to bottom of hem to secure in place.

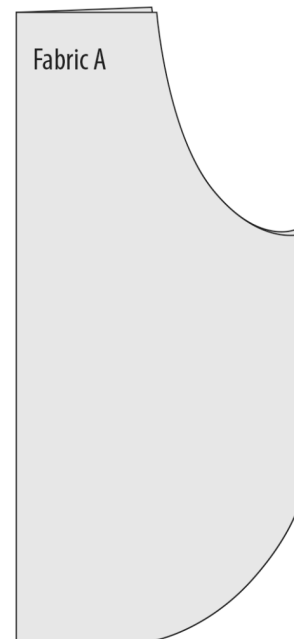

5. Place **Fabric B** pocket right side down on bottom edge of right side of **Fabric D** lining rectangle. Top with **Fabric A** apron front, right side down.

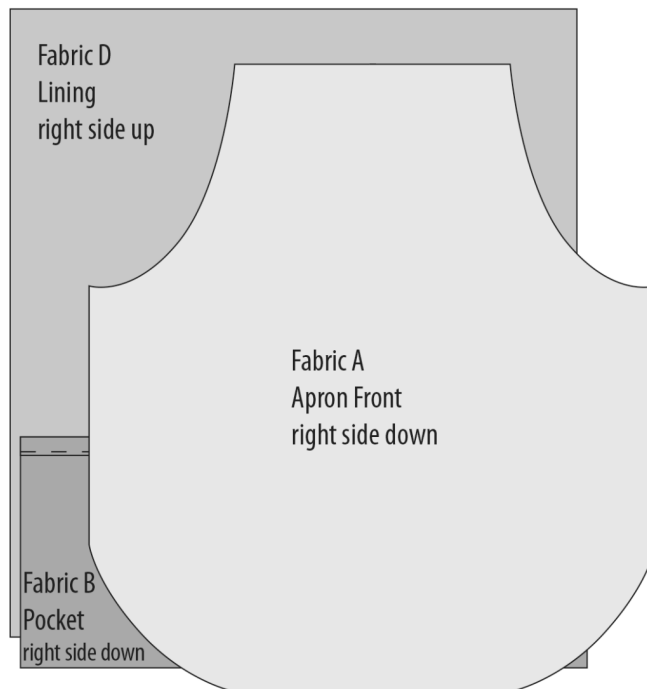

BASIC Apron #1 Featuring Lakefront

6. With a 1/2" seam allowance, stitch across top edge and around the sides and bottom edges of apron front.

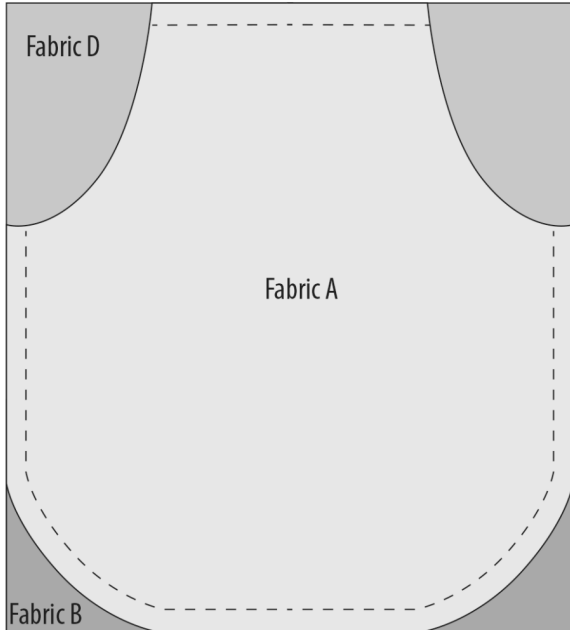

7. Trim lining and pocket even with curved edges of **Fabric A** apron front. Along bottom curved seam, grade seam allowances so they vary in width to reduce bulk. Do not trim seam allowances to less than 1/4". To further reduce bulk, clip seams no more than 1/4" into seam allowance.

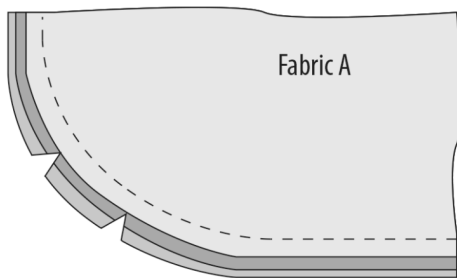

Shading of diagrams may vary depending on fabrics used.

8. Turn apron right side out using caution not to stretch the bias cut armholes. Press seams flat. Pin layers of each armhole together. Topstitch around entire apron 1/4" from edge. Topstitch 4" from bottom from side to side. Stitch divisions for pocket as desired.

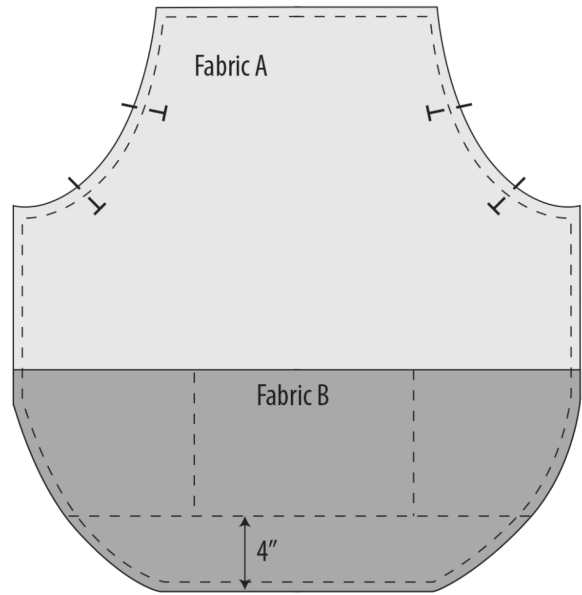

9. Cut a 4" x 4" triangle from one corner of **Fabric C**. Cut remaining **Fabric C** into 2-1/2" wide bias strips, measuring from the cut edge.

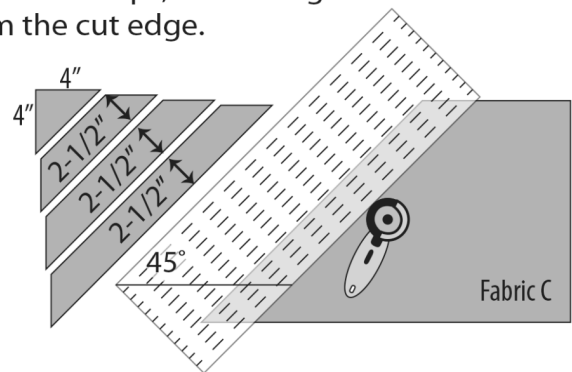

10. Sew **Fabric C** bias strips together with diagonal seams and right sides together until bias strip is at least 108" long.

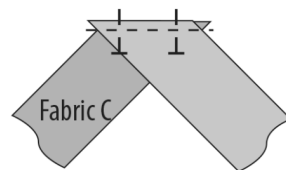

BASIC Apron #1 Featuring Lakefront

11. Trim 'points' of seam allowance even with edges of bias strips as needed.

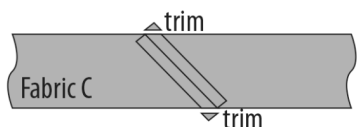

12. Cut **Fabric C** strip into two equal lengths. Press long edges of **Fabric C** bias strips to wrong side 1/4". Fold nearly in half to create bias binding, so one side is slightly narrower than the other.



Shading of diagrams may vary depending on fabrics used.

13. Measure 14" of bias binding and pin to top corner of an armhole so narrow side is on top. Pin binding to armhole catching all layers. Topstitch along full length of bias strip, sewing from the narrow side to be sure to catch the wider side on the bottom. Backstitch on each end of armhole to secure tightly. Tie a knot in each end of bias strip. Repeat on other side.

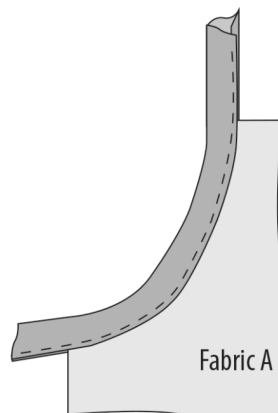

14. Put apron on. Tie neck ties so apron hangs comfortably. Tie side ties around back. Enjoy!

